

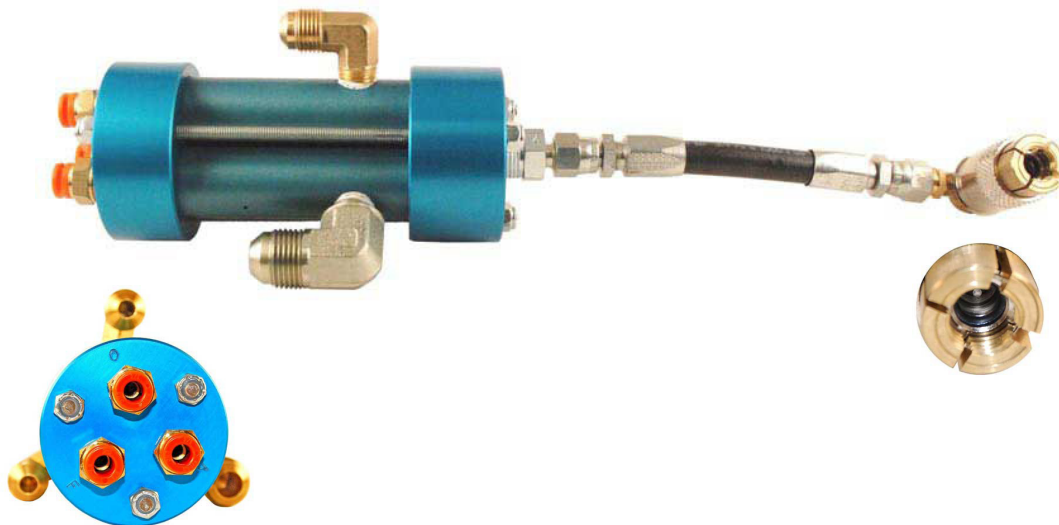

Series 130 Evacuation & Refrigerant Charging Tool with Manual Coupler for 1/4" Schrader Fitting

FEATURES

- Minimum refrigerant loss
- Manual connection force
- Manual operation, upon connection to fitting
- High vacuum and refrigerant and oil flow rates
- Air operated poppet valves
- Lightweight
- Separate Refrigerant and oil vacuum connections
- Connects to 1/4 flare fitting with Schrader core



Reduce labor content and minimize emission of refrigerant to the atmosphere!

The Series 130 Charging Tool is the interface adapter for a refrigerant/oil charging system. It is designed for direct connection to 1/4 flare thread with Schrader core process fittings for evacuation and refrigerant/oil charging, with de minimis refrigerant loss to atmosphere.

Tool valve operation is controlled automatically after the operator positions coupler on the process fitting and starts cycle. Charging machine cycle includes evaluation, vacuum check, and refrigerant charging. The operator will remove coupler by pulling on sleeve to release clamping.

The Series 130 Charging Tool is designed to operate with Mass Flowmeter Refrigerant Charging System. Tools with automatic clamping are available. Please contact PCU for further information.

The tool contains three separate fluid circuits, controlled by air pilot pressure, which may be used for vacuum, refrigerant, salvage, oil, or any other fluid up to 500 psig.

Save money with the PCU Series 130 Charging Tool. Contact our Order Department at (1-937-299-5594) with your application and equipment specifications.

Series 130 Evacuation & Refrigerant Charging Tool with Manual Coupler for 1/4" Schrader Fitting

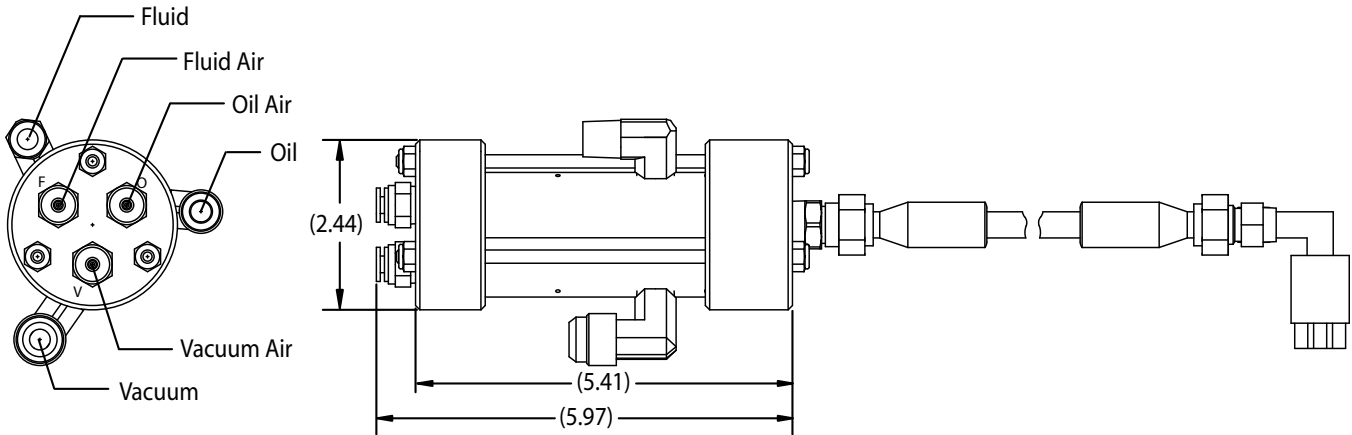

* For other configurations and multiple poppet valves, please contact PCU Engineering for dimensions and availability.

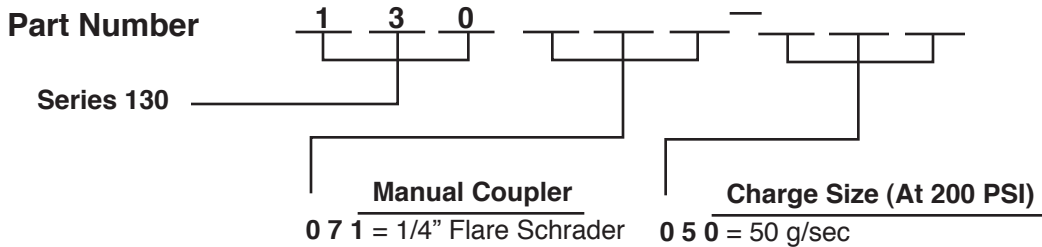

Refer to PB047 for Series 130 with Manual Coupler and PB049 for Series 130 with Power Coupler.

TECHNICAL SPECIFICATIONS:

Weight 2.6 lbs (1.18 kg)
 Vacuum range 0-760 TORR (0-760 mmHg)
 Refrigerant HFC-134a
 Opens with pressure air @ 70 psig
 Oil Polyolester or PAG
 Opens with pressure air @ 70 psig
 Standard Charge Rate 50 g/s
 Maximum Refrigerant Pressure 520 psig
 Vacuum port fitting 1/2" JIC flare
 Refrigerant 3/8" JIC flare
 Oil Port Fitting 3/8" SAE flare

Air pilots (Vacuum, Refrigerant, Oil)
 Air supply pressure 70 PSIG (4.9 kg/cm²)
 Air port fittings 1/4" dia. one touch connectors
 Tool Valve Block Flow Capacity (Refrig., Vacuum, Oil)
 0.9Cv (Typical)
 Process fitting compatibility 1/4 Flare Schrader Valve
 Process fitting nose seal O-Ring
 Oil compatibility Polyolester or PAG



Production Control Units, Inc.

2280 West Dorothy Lane, Dayton, Ohio 45439-1892 Phone (937) 299-5594 FAX: (937) 299-4843
 ©Production Control Units, Inc. U.S.A. Web: www.pcuinc.com