

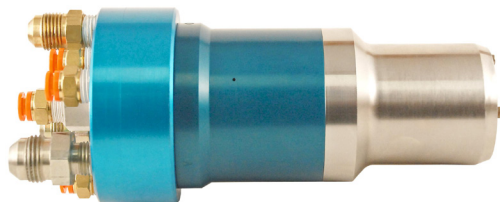

Series 104 Evacuation & Refrigerant Charging Tool

FEATURES

- Minimum refrigerant loss
- Automatic disconnect capability
- Zero connection force
- Automatic operation, upon connection to fitting
- High vacuum and refrigerant and oil flow rates
- Air operated
- Lightweight
- Separate Refrigerant and oil vacuum connections



104001-700 Straight Manifold



104001-002 Straight Manifold



104001-004 90° Manifold

Reduce labor content and minimize emission of refrigerant to the atmosphere!

The Series 104 Charging Tool is the interface adapter for a refrigerant/oil charging system. It is designed for direct connection to quick-connect HFC-134a A/C hi-side process fittings for evacuation and refrigerant/oil charging, with de minimis refrigerant loss to atmosphere from the tool, and the additional benefit of automatic disconnect at cycle completion.

Tool operation is controlled automatically. The operator only has to locate the tool on the process fitting, it clamps, seals, and initiates the charging machine cycle including evacuation, vacuum check and refrigerant charging. After cycle completion, the process fitting seal is resealed and the tool disconnects.

The clamping mechanism used is the time proven ball lock method. The eight hardened steel balls are constrained in the charge gate body, and secured onto the ball groove taper on the process fitting by the locking sleeve. Securing the balls on the taper assures positive force on

the nose seal.

The Tool is designed to operate with the Mass Flowmeter Refrigerant Charging System. It is also adaptable to applications that require air-piloted valve operation with automatic clamping and fitting stem operation.

The tool contains three separate fluid circuits, controlled by air pilot pressure, which may be used for vacuum, refrigerant, salvage, oil, or any other fluid up to 520 psig.

Standard series 104 is designed for high flow rate up to 300 g/sec at 200 PSI. Slower flow rates are available please contact PCU Engineering with your application and equipment specifications.

Save money with the PCU Series 104 Charging Tool. Contact our Order Department (1-937-299-5594) with your application and equipment specifications.

Compucharge Series 104 Evacuation & Refrigerant Charging Tool

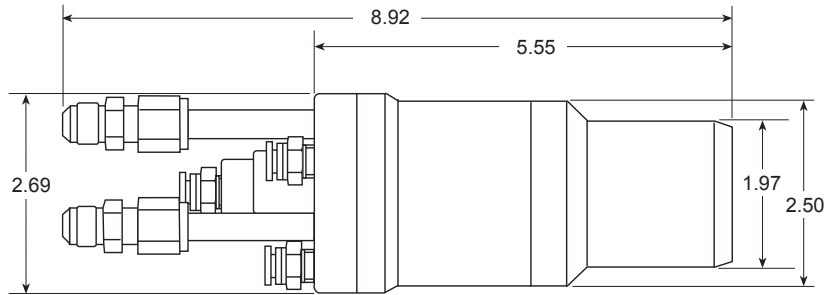
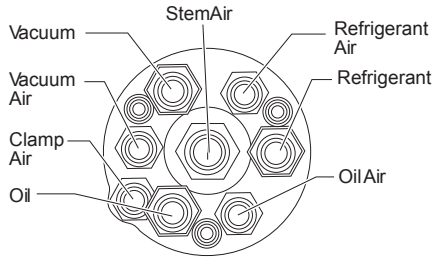

(104001-002 Shown)

**STANDARD STOCK PART NUMBERS: 104001-002 (STRAIGHT MANIFOLD)
104001-004 (90° MANIFOLD)**

TECHNICAL SPECIFICATIONS:

Weight	4.25 lbs (1.9 kg)	Air pilots (Vacuum, Refrigerant, Oil, Clamp & Stem air)
Vacuum range	0–760 TORR (0–760 mmHg)	Air supply pressure 70 PSIG (4.9 kg/cm ²) Air port fittings 1/4" dia. one touch connectors
Refrigerant	HFC-134a Opens with pressure air @ 60 psig	Flow Capacity (Refrig., Vacuum, Oil). 0.9Cv (typical)
Oil	Polyolester or PAG Opens with pressure air @ 60 psig	Process fitting compatibility SAE J639 Process fitting nose seal Molded Process fitting clamp system PCU BallLoc
Tool flow rate (typical)	300 g/sec at 200 PSI (Contact PCU for Slower Flow Rates)	Oil compatibility Polyolester or PAG
Max Refrigerant Pressure	300 psig @ 60 psi air	
Vacuum port fitting	1/2" JIC flare	PATENTS:
Refrigerant & oil port fitting	3/8" JIC flare	This tool is manufactured under U. S. Patent No. 6,298,886

Contact PCU for extended nose Series 104. Series 104 can easily be modified to mate with Series 250: Hansen 2HK, 3HK, and J639 Low-Side Fittings. Please contact PCU Engineering for Custom Series 104 to meet your application.



Production Control Units, Inc.

2280 West Dorothy Lane, Dayton, Ohio 45439-1892 Phone (937) 299-5594 FAX: (937) 299-4843
©Production Control Units, Inc. U.S.A. Web: www.pcuinc.com